



A JohnsonDiversey Company

CMA-44H
High Temperature
44" Conveyor
Dishwasher

Item. # _____



Optional motor cover.

FEATURES:

- 205 racks / 820 covers per hour.
- Economical to operate. Uses only .94 gallons of water per cycle.
- Unique 3-stage washing process provides pre-wash, power wash and final rinse all in a 44" machine.
- Automatic soil purging system filters wash water and traps plate debris into an external tray. Tray can be easily removed for dumping contents.
- Heavy duty 12 and 14 gauge 304 stainless steel construction offers durable performance and years of trouble free operation.
- Built-in chemical resistant industrial 10kW heater is proven to be more durable than commercial style heaters.
- Large 19" high opening accommodates larger items and utensils.
- Auto start/stop makes operation safe and easy.
- Includes table limit switch and rack saver arm that protect the machine, dishracks and table from damage.
- Two speed settings available for optimum cleaning performance.

Spec. # _____



Rack saver arm protects the machine, dishracks and table from damage.



3-stage washing process provides pre-wash, power wash and final rinse all in a 44" machine.

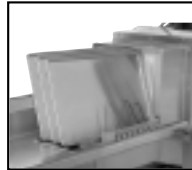

Large 19" high opening accommodates larger items and utensils.



Shown with optional corner feed table. Available right or left.



Shown with optional vent hoods and damper controls.



Top mounted controls include easy to read temperature gauges and complete operating instructions.

AIA # _____

CMA Dishmachines 12700 Knott Avenue Garden Grove, CA 92841 • 800-854-6417 • 714-898-8781 • Fax: 714-895-2141 • www.cmadishmachines.com

Lit#0109

CMA reserves the right to modify specifications or discontinue models without prior notification.

Printed in the U.S.A.

© 2002 CMA, Inc.



A JohnsonDiversey Company

CMA-44H
High Temperature
44" Conveyor
Dishwasher

Spec. #

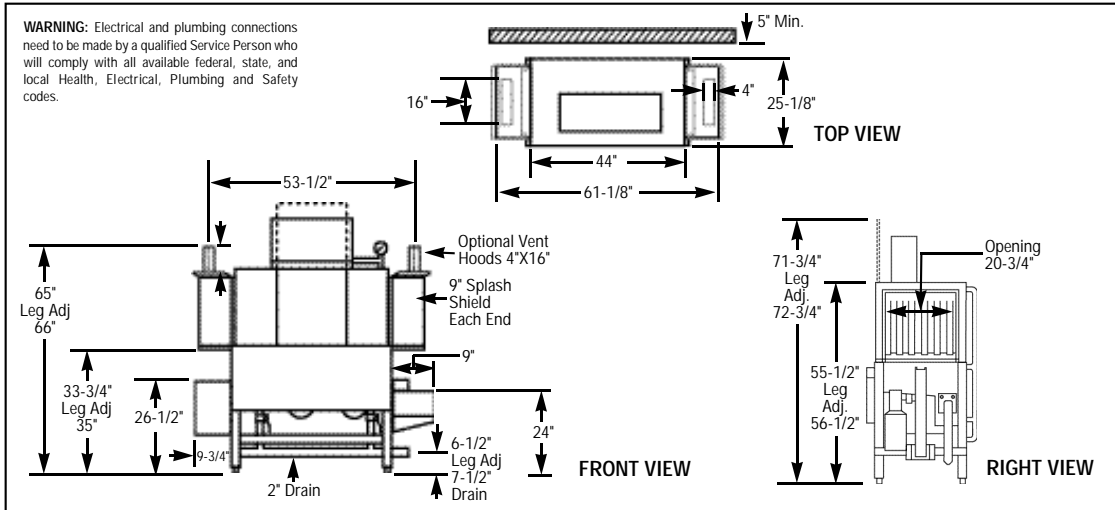

Specifications:

MODEL CMA-44H	USA	METRIC	USA	METRIC
OPERATING CAPACITY				
RACKS PER HOUR (NSF RATED)	205	205		
CONVEYOR SPEED	5.7 FT./MIN.	(174 CM/MIN.)		
DRAIN	2"	-		
CONVEYOR MOTOR HP	1/3	1/3		
WASH PUMP MOTORS HP (2)	1	1		
WATER INLET - FILL	3/4"	-		
WATER INLET - FINAL RINSE	1/2"	-		
WASH TANK CAPACITY				
PRE-WASH	4.25 GAL	(16.0 L)		
WASH	11.75 GAL	(44.5 L)		
TOTAL	16.0 GAL	(60.5 L)		
WASH PUMP CAPACITY				
EACH	73 GPM	(276 LPM)		
OPERATING TEMPERATURE				
WASH - °F (MIN)	150°F-160°F	(68°C-71°C)		
FINAL RINSE - °F (MIN)	180°F-195°F	(82°C-90°C)		
WATER CONSUMPTION				
PER RACK (RINSE)	.94 GAL	(3.6 L)		
PER HOUR (RINSE)	192 GPH	(726.6 LPH)		
DIMENSIONS				
DEPTH	25-1/8"	(64cm)		
WIDTH	44"	(111.7cm)		
HEIGHT	55-1/2"-56-1/2"	(140.97-143.51cm)		
STANDARD TABLE HEIGHT	34"	(86cm)		
MAX HEIGHT CLEARANCE FOR DISHES	19"	(48cm)		
STANDARD DISHRACK DIMENSIONS	1	1		
	19-3/4"X19-3/4"	(50X50cm)		
ELECTRICAL RATING	VOLTS	PHASE	AMPS	
	208	1	61	
	240	1	65	
	208	3	38	
	240	3	42	
BOOSTER HEATER	10kW			
SPECIFY DIRECTION OF RACK TRAVEL (RIGHT TO LEFT, LEFT TO RIGHT) WHEN ORDERING				
CMA-44H EXHAUST VENTILATION REQUIREMENTS AT 100% CAPACITY CFM				
ENTRANCE	END 200 MAX	DISCHARGE	END 400 MAX	TOTAL CFM 600 MAX
SHIPPING WEIGHT				
APPROXIMATE	662#			(300kg)

Summary Specifications: Model CMA-44H

The Model CMA-44H high temperature conveyor dishwasher meets NSF, UL, and CUL sanitation and construction standards utilizing 180°F final rinse water. The CMA-44H performs three separate washing functions including a built-in pre-wash, all in a 44" space. The CMA-44H washes up to 205 racks per hour and uses a minimum .94 gallons of water per rack while achieving sparkling, clean, dry dishes.

Available Models

- CMA-44H R/L Right to Left
- CMA-44H L/R Left to Right

Available Options

- Corner Feed Table
- Vent Hood with 4" x 16" Vent and Damper Control (2 per set)
- Alternative electrical options
- C-24 Hatco Booster Heater (40° rise), other sizes available
- Also available at 167 racks/hr
- Stainless steel dishtables
- Auto Fill
- Motor Cover
- Drain Water Tempering Kit

AIA #